

Tune Up Kit

P60101 INSTALLATION INSTRUCTIONS

ENGINE APPLICATION:

DETROIT S60 11.1L/12.7L/14.0L

FOR ENGINE BRAKE MODEL:

PACBRAKE

P-61/P-63/P-63A/P-63B/P-63C

REMOVAL OF THE HOUSINGS FROM THE ENGINE

- A) Thoroughly clean the engine around the valve cover and remove. Two piece cover remove only the top.
- B) Mark the housings position 1, 2 and 3 so they can be installed in their original position on the engine.
- C) Disconnect the wires from the solenoids.
- D) Loosen the slave adjusting screw lock nuts.
- E) Loosen and remove the hold down capscrews, lift the housings from the engine.

DISASSEMBLY AND ASSEMBLY OF THE BRAKE HOUSINGS

- A) Place the housings (in order) on a clean work bench. Note: when removing all parts keep them in order of their original location for installation later.
- B) Remove the slave piston adjusting screws, inspect the plungers for spring pressure.
- C) Remove the solenoids (use the proper tool only, PN P11494). Adjustable pliers can damage the coil. Remove all seals and discard.
- D) Remove the control valves and accumulators (use caution and wear eye protection as the cover is under spring pressure). Apply pressure on the cover and remove the 1/4" capscrews. Remove the control valve springs and control valves. The control valves should slide out easily using needle nose pliers or a magnet, if not, inspect the bore and control valve carefully for damage. Retain/reuse cover plates, and spring plates. Discard capscrews, springs and control valves. Single springs supplied replaces all previous multi-spring combinations.
- E) Remove springs and accumulators. The accumulators should slide out easily using a magnet, if not, inspect the bore and accumulator carefully for damage. Discard springs. Single springs supplied replace all previous multi-spring combinations, except for P-63B which uses 2 springs. See Accumulator Application Chart on reverse side.

- F) Turn the housings over to remove the master piston return springs. Loosen and remove the capscrews fastening the springs to the housings. The master pistons should slide out easily, if not, carefully check the piston and bore for damage. Discard the capscrews only retaining the springs and washers, for reassembly. Once the master piston capscrews have been removed, clean the threads with a 1/4" 20 NC tap to remove any residual loctite.
- G) Remove the capscrews which fasten the slave piston bridge and springs to the housing. Remove the slave piston bridges, springs and slave pistons. The slave pistons should slide out easily, if not, carefully check the piston and bore for damage. Check the fit of the piston in its bore for wear, excessive clearance between the piston and bore will cause low performance. Discard the capscrews and springs. Once the shoulder bolts have been removed, clean the threads with a 1/4" 20 NC tap to remove any residual loctite.
- H) Wash the housings thoroughly in clean OSHA approved solvent, dry with compressed air. Wash all parts in clean solvent, keeping them in relation to their original position.

IMPORTANT ASSEMBLY NOTES

- Assemble all parts into the housings using clean engine oil in the reverse procedure.
- Clean slave pistons separately. Do not allow slave piston carbide wear pad to contact any other components or damage will occur.
- SOLENOID INSTALLATION: It is important not to twist or cut the solenoid seals. Lubricate seals with clean engine oil and torque 200 lbs. in.
- P-61, P-63, P-63A and P-63B have slave pistons with bleed holes which must go in the inner locations.
- Control valve and accumulator springs are colour coded, they must be installed as per the Accumulator Spring Application Chart on reverse side of this sheet.
- Torque slave piston shoulder bolts to 100 lbs. in., apply 242 Loctite to the threads. Check that shoulder bolt is installed to machined surface. If a gap exists between the machined surface and the bolt's shoulder insert a 1/4-20 NC tap to clean the threads.
- Master piston springs must be aligned with both legs centered in the groove. Torque capscrew to 100 lbs. in.
- Master pistons with ball checks must be checked for spring pressure and leakage.
- Install on engine as per Pacbrake L2008 installation manual. If manual is not available contact Pacbrake at 1-800-663-0096 or download from www.pacbrakeoem.com

Tune Up Kit

P60101 KIT PARTS

ENGINE APPLICATION:
DETROIT S60

FOR ENGINE BRAKE MODEL:
PACBRAKE
P-61/P-63/P-63A
P-63B/P-63C

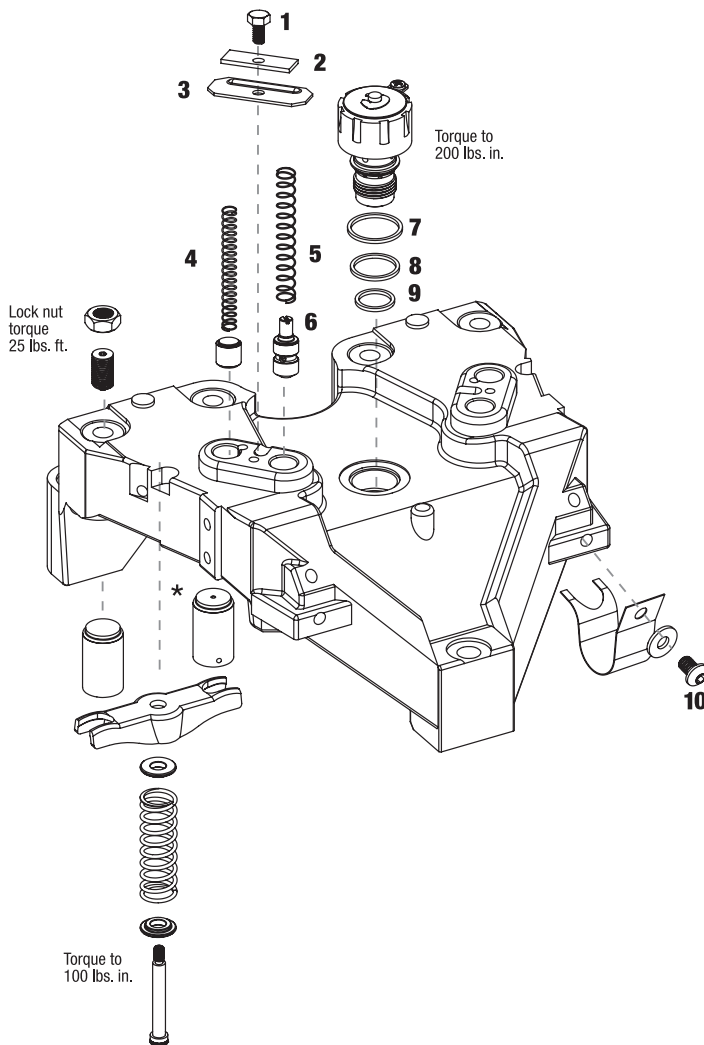

ILLUS. #	PART#	DESCRIPTION	QTY.
1	P01492	CAP SCREW	6
2	P60019	COVER SPRING	Retain/Reuse
3	P34650	COVER - CONTROL VALVE	6
4	SEE ACCUMULATOR SPRING APPLICATION CHART		
5	P60053	SPRING - C.V. (BLUE)	6
6	P01500	CONTROL VALVE (2 HOLE)	6
7	P01081	SEAL RING - UPPER	3
8	P01082	SEAL RING - CENTER	3
9	P01083	SEAL RING - LOWER	3
10	P03790	SCREW - S. H. BUTTON	6

***CAUTION: P-61, P-63, P-63A, P-63B**
DO NOT INTERMIX SLAVE PISTONS.
PISTONS WITH CROSS-DRILLED HOLES MUST BE IN THE
INNER BORES.

ACCUMULATOR SPRING APPLICATION CHART		P-61	P-63	P-63A	P-63B	P-63C
4	P60054 Accum. Spring (Natural)	X	X	X		
4a	P60059 Accum. Spring - Inner (Yellow)				X	
4b	P60061 Accum. Spring - Outer (Red)				X	X

Housing Serial Number ID Chart

P-63	023061 to 038599
P-63A	550099 to 567521
P-63B	038600 to 043977
P-63C	044601 to 072350

PACBRAKE[®]
ENGINE & EXHAUST BRAKES

Need to know more ... 800-663-0096

www.pacbrake.com