

TUNE UP KIT

P80037

L5253

Engine Application:

**Detroit Diesel
Series 60
12.7L / 14.0L**

Fits Models:

MY2001/2002 — P-80A

MY2002+ — P-80C
(Built after Sept 30, 2002)

Solenoid torque not to exceed 150 lb.in.

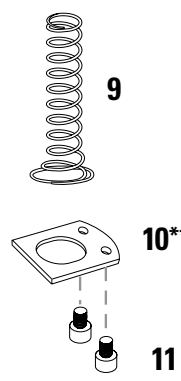
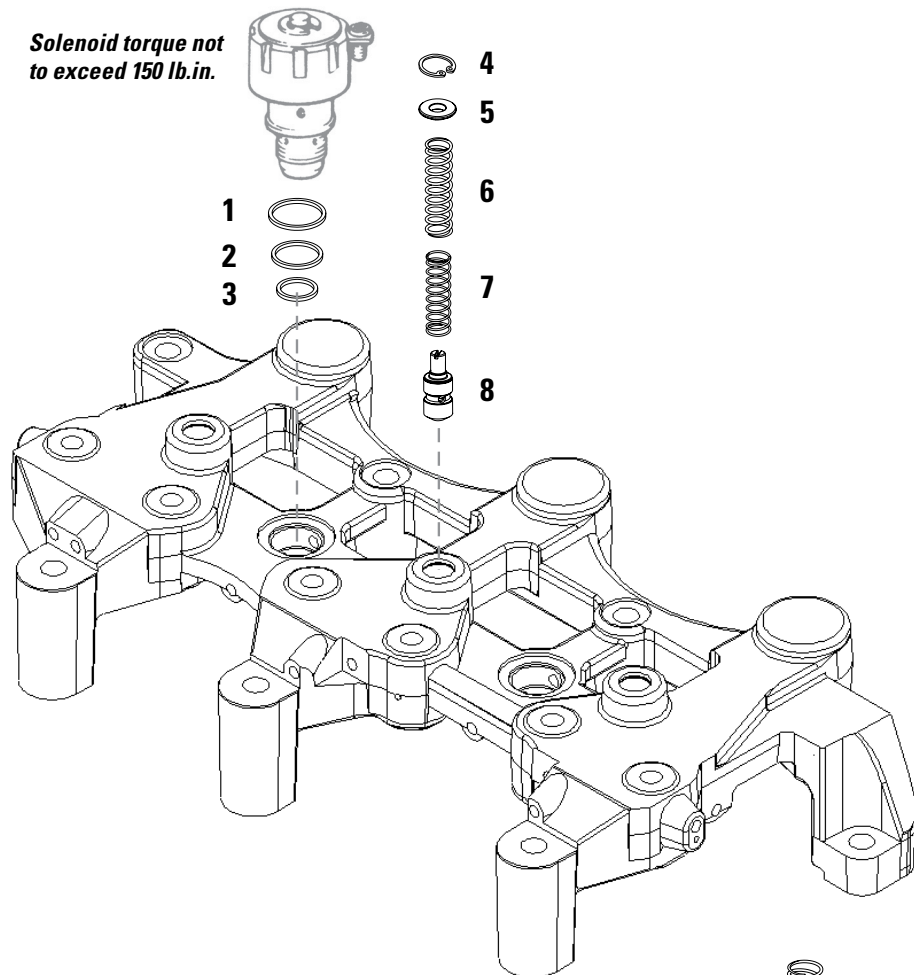

ILLUS.#	PART #	DESCRIPTION	QTY.
1	P01081	Upper Solenoid Viton Seal	3
2	P01082	Center Solenoid Viton Seal	3
3	P01083	Lower Solenoid Viton Seal	3
4	P15561	Snap Ring	6
5	P38015	Plain Washer	6
6	P11434	Outer Control Valve Spring	6
7	P11435	Inner Control Valve Spring	6
8	P01500	Control Valve	6
9	P80031	Master Link Spring	6
10	P80029	Master Piston Retainer	N/A**
11	P80012	Socket head Retaining Screw	12

**** PLEASE NOTE: As of October 24, 2022,
Part No: P80029 is obsolete.
The original part must be reused.**



AFTERMARKET BY
PACBRAKE

USA 1670 Grant Ave, Blaine, WA 98230 - 800.663.0096 / pacbrake.com

CANADA 26688 56 Ave, Langley, BC V4W 3X5 - EMAIL info@pacbrake.com - FAX 604.882.9278



INSTALLATION INSTRUCTIONS

REMOVAL OF THE HOUSINGS FROM THE ENGINE

- A) Clean the engine around the valve cover and check gasket, as a new one is not supplied. On two piece valve covers, remove the top only.
ATTENTION: Before removal of housings, make certain the serial number tag reads P-80A and NOT P-80.
- B) Loosen the 12 slave piston adjusting screw lock-nuts.
- C) Remove wires to the solenoids.
- D) Loosen the housing hold down bolts evenly.
- E) Remove both housings from the engine.

Engine Application:

**Detroit Diesel
Series 60
12.7L / 14.0L**

Fits Models:

MY2001/2002 — P-80A

MY2002+ — P-80C
(Built after Sept 30, 2002)

DISASSEMBLY AND ASSEMBLY OF THE BRAKE HOUSINGS

- A) Place the housings on a clean work bench.
PLEASE NOTE: When removing all parts keep them in order of their original location for assembly later.
- B) Remove the slave piston adjusting screws.
- C) Use the proper tool, remove the solenoids. Adjustable pliers can damage the coil. Remove seals and discard.
- D) Remove the control valve retaining rings. **Use caution** and wear eye protection, as the washers are under spring pressure! Remove the springs and control valves. The control valves should slide out easily using needle nose pliers or a magnet. If not, inspect the bore and control valve for damage. Discard control valves, springs, washers and retaining rings.
- E) Turn the housings over to remove the master piston retainers. **DO NOT discard retainers as they must be reused.** A heat gun may be required to remove the capscrews as Loctite is applied at assembly. The piston should slide out easily. If not, inspect the bore and piston for damage. Discard capscrews, springs and washers. Once the master piston capscrews have been removed, clean the threads with a ¼" 20 NC tap to remove any residual loctite.
- F) Slave piston removal. **Use caution** and wear eye protection, as the slave piston return springs are under pressure! Removal of the slave piston assemblies is for cleaning and inspection only.
- G) Wash all the housings and parts in clean OSHA approved solvent, keeping the parts in relation to their original position. Wash the parts individually to avoid damage by contact with hardened surfaces. Once the shoulder bolts have been removed, clean the threads with a ¼" 20 NC tap to remove any residual loctite. Check the fit of the piston in its bore for wear, excessive clearance between the piston and bore will cause low performance.
- H) Assemble all parts into the housing using clean engine oil in the reverse procedure. Master piston return spring **MUST** be installed with the larger end against the retainer. Make sure all retaining rings are seated in their groove. During solenoid installation, it is important not to twist or cut the seals. Lubricate the seals with clean engine oil and torque to 150 lbs. in. Apply service removable Loctite 242 to the slave piston shoulder bolts and master piston retainer capscrews. Torque shoulder bolts to 100 lbs. in. and ensure the bolt is installed to machine surface. If a gap exists between the machined surface and the bolts shoulder, retap the ¼"-20 NC tap to clean the threads.
- I) Install on engine as per manufactures specifications.

For additional information visit our website @ www.pacbrake.com or call 1-800-663-0096



AFTERMARKET BY
PACBRAKE

USA

1670 Grant Ave, Blaine, WA 98230

CANADA

26688 56 Ave, Langley, BC V4W 3X5

• 800.663.0096 / pacbrake.com

• EMAIL info@pacbrake.com

• FAX 604.882.9278

