

## Subject:

### PRXB™ AND CAST ELBOW SPECIAL INSTALLATION INSTRUCTIONS

## Engine:

**NAVISTAR 3800, 4000, 5000, AND 7000**  
Series comes with DT466/DT530  
& comes with 90° pipe

- 1) Remove the existing header pipe, save the turbocharger V-clamp for reuse.
- 2) At the oil pan remove the crankcase breather tube clamp.
- 3) Connect the cast elbow to the turbocharger as shown using one of the two V-clamps provided in the kit. Tighten the clamp enough to hold the elbow but still allow for rotational adjustment.
- 4) Connect the Pacbrake PRXB to the end of the cast elbow using the remaining V-clamp provided. Tighten the clamp enough to hold the Pacbrake but still allow for rotational adjustment.
- 5) Connect the exhaust adapter provided to the outlet of the Pacbrake using the original V-clamp. Tighten the clamp enough to hold the adapter in place.
- 6) Cut the original header pipe to length and install.
- 7) Adjust the cast elbow and exhaust brake to provide adequate clearance and alignment with the header pipe.
- 8) Torque the V-clamps to 10 lbs ft., install the C11859 band clamp provided then torque the band clamp to 50 lbs ft.
- 9) Install the bracket provided and original clamp to relocate the lower end of the crankcase breather tube.
- 10) Retorque all the clamps after road test.

## Factory Layout

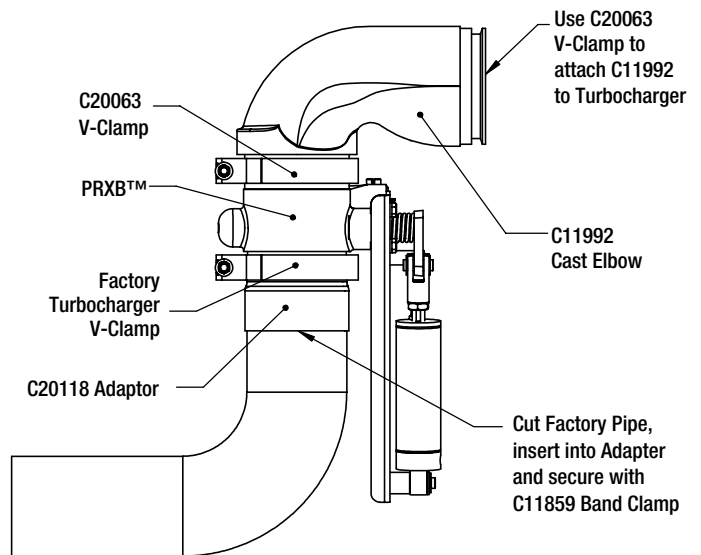
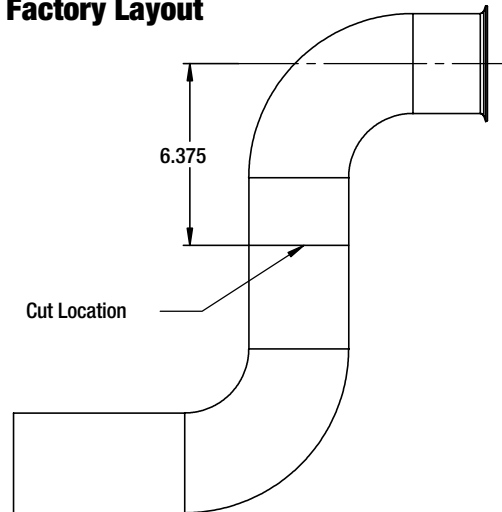

## Pacbrake PRXB™ Layout