

Tune Up Kit

P20532 INSTALLATION INSTRUCTIONS

ENGINE APPLICATION:
DETROIT S60

FOR ENGINE BRAKE MODEL:
JACOBS 760A/765/765A

REMOVAL OF THE HOUSINGS FROM THE ENGINE

- A) Thoroughly clean the engine around the valve cover and remove. Two piece cover remove only the top.
- B) Mark the housings position 1, 2 and 3 so they can be installed in their original position on the engine.
- C) Disconnect the wires from the solenoids.
- D) Loosen the slave adjusting screw lock nuts.
- E) Loosen and remove the hold down capscrews, lift the housings from the engine.

DISASSEMBLY AND ASSEMBLY OF THE BRAKE HOUSINGS

- A) Place the housings (in order) on a clean work bench. Note: when removing all parts keep them in order of their original location for installation later.
- B) Remove the slave piston adjusting screws, inspect the plungers for spring pressure.
- C) Remove the solenoids (use the proper tool only, adjustable pliers can damage the coil). Remove all seals and discard.
- D) Remove the control valves (use caution and wear eye protection as the washer is under spring pressure). Apply pressure on the washer then compress the retaining ring and remove both. Remove the springs, collars and control valves. The control valves should slide out easily using needle nose pliers or a magnet, if not, inspect the bore and control valve carefully for damage. Discard retaining rings, washers, springs, collars, and control valves.
- E) Remove the accumulators (use caution and wear eye protection as the washer is under spring pressure). Apply pressure on the washer then compress the retaining ring and remove both. Remove springs and accumulators. The accumulators should slide out easily using a magnet, if not, inspect the bore and accumulator carefully for damage. Discard the retaining rings, washers and springs.
- F) Turn the housings over to remove the master piston return springs. Loosen and remove the capscrews fastening the springs to the housings. The master pistons should slide out easily, if not, carefully check the piston and bore for damage. Discard the capscrews, springs and washers.

- G) Remove the capscrews and washers which fasten the slave piston return springs to the housing. Remove the slave piston bridges and slave pistons. The slave pistons should slide out easily, if not, carefully check the piston and bore for damage. Check the fit of the piston in its bore for wear, excessive clearance between the piston and bore will cause low performance. Discard the capscrews and washers.
- H) Wash the housings thoroughly in clean OSHA approved solvent, dry with compressed air. Wash all parts in clean solvent, keeping them in relation to their original position.

IMPORTANT ASSEMBLY NOTES

- Assemble all parts into the housings using clean engine oil in the reverse procedure, making sure all retaining rings are seated in the groove.
- SOLENOID INSTALLATION: It is important not to twist or cut the solenoid seals. Lubricate seals with clean engine oil and torque 12 point socket applications to 110 lbs. in. and 6 point socket applications to 180 lbs. in.
- Slave piston bridges must be installed with the leveling screws towards the center of the housing.
- Torsion spring: Prior to assembly, be sure there are no burrs or sharp edges on the machined surface where the torsion spring will be secured. If some are present use a stone, or file lightly until they are removed. Using the existing springs, the new button head screws and washers, mount the torsion springs with the legs extending over the bridge and centered below the screw and washer. Using a 7/32" hex key wrench, screw down the button head screw until it makes contact with the washer. Place a bar through both torsion spring coils and push the spring toward the slave piston. Failure to do so may cause interference between the spring and intake valve. Use a hand torque wrench (not a pneumatic or impact) to tighten the button head screw to 15 lbft. (20 N·m). DO NOT OVER TIGHTEN OR ALLOW THE SPRING TO ROTATE MISALIGNING THE SPRING FEET. After completing the installation, be sure the gap between the outside diameter of the coils on either side of the spring and bridge is equal and there is no distortion of the spring coils.
- Master piston springs must be aligned with both legs centered on the piston. Torque capscrew to 100 lbs in.
- Control valve collars must be installed with the longer end up, if installed upside down the brake will not function.
- Install the new power lash screws loosely, DO NOT TIGHTEN.
- Install on engine as per manufacturers specifications.

Tune Up Kit

P20532 KIT PARTS

ENGINE APPLICATION:
DETROIT S60

FOR ENGINE BRAKE MODEL:
JACOBS
760A/765/765A

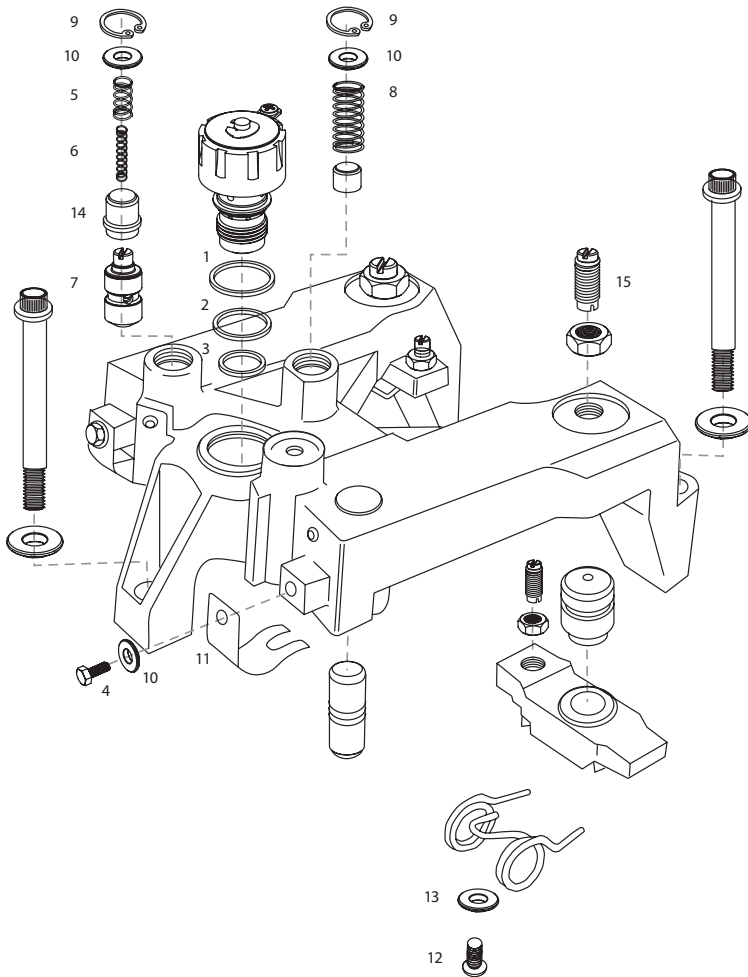

ILLUS. #	PART#	DESCRIPTION	QTY.
1	P01081	UPPER SOLENOID VITON SEAL	3
2	P01082	CENTER SOLENOID VITON SEAL	3
3	P01083	LOWER SOLENOID VITON SEAL	3
4	P01492	CAPSCREW	6
5	P01519	OUTER CONTROL VALVE SPRING	6
6	P07500	INNER CONTROL VALVE SPRING	6
7	P11930	CONTROL VALVE	6
8	P12990	ACCUMULATOR SPRING	3
9	P12991	RETAINER RING	9
10	P01030	WASHER	15
11	P17658	MASTER PISTON SPRING	6
12	P19740	BUTTONHEAD SCREW	6
13	P19741	SLAVE SPRING WASHER	6
14	P16557	CONTROL VALVE COLLAR	6
15	P20382	POWER LASH	6

SEE INSTALLATION INSTRUCTIONS ON REVERSE SIDE.