

Installation MANUAL



Compressor Installation Kit Only. Compressor Not Included.

HP625 AIR COMPRESSOR INSTALLATION KIT
HP10116 (12 volt compressors) & HP10116-24 (24 volt compressors)

INSTALLATION MANUAL - AIR COMPRESSOR INSTALLATION KIT, L5939

Thank you and congratulations on the purchase of a Pacbrake air compressor with unloader installation kit. This kit is a sub group to a Pacbrake HP10625 or HP10625-24 air compressor and is designed to meet the requirements of the air compressor. This kit contains the basic electrical system and plumbing components needed to operate the air compressor (air compressor, tank kit and accessory kits are sold separately).

Please read these instructions carefully to ensure you can complete the installation once started. If you have questions, please call our customer service technicians 1.800.663.0096.

Before starting ensure the kit contains all the items shown in the photo.



NOTE: This kit includes "push to connect" airline fittings. They require the end of the airline to be round, square and cleanly cut to ensure the internal seal will not leak air. The airline must only be cut with a sharp razor knife. Using scissors, a hose cutter, or wire cutters will distort the airline causing the connection to leak air past the o-ring seal.

Follow the air compressor mounting requirements provided with the air compressor.

PLUMBING THE AIR COMPRESSOR

- 1 Once the air compressor mounting location has been chosen and the mounting holes are drilled, the manifold can be installed. The air manifold assembly is mounted to the top of the two mounting feet on the discharge side for vertical head and the opposite side of the head for horizontal head models. The air manifold provided contains a pressure switch, unloader valve, one way check valve, one air inlet port and two air outlet ports.
- 2 It is easier to install the two air outlet port fittings before mounting the manifold to the compressor. One outlet port is the air supply to the tank and the other port can be used to supply air to an accessory, a gauge or be plugged off for future use (a 1/4" NPT plug is provided). Use thread sealant or Teflon tape on all fittings installed to prevent air leaks.
- 3 Using the fittings provided, connect the copper discharge line from the compressor head to the manifold inlet port. The length of copper line is designed for the horizontal compressor head. Vertical head installations will require this line to be cut before the bend with a tubing cutter.

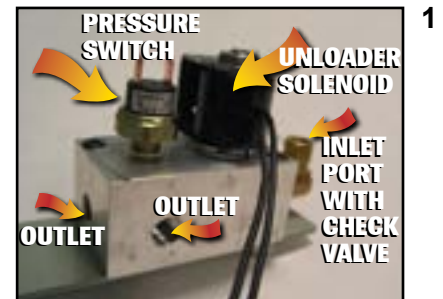

ELECTRICAL CONNECTIONS

WARNING: DO NOT LENGTHEN ANY WIRE LENGTHS

- 4** Locate the wiring harness and self tapping screw provided. The harness has a pre-wired relay receptacle. Remove the relay. Using the self tapping screw, mount the relay receptacle within 18" of the positive battery terminal.

Do not re-install the relay at this time (it is installed in step 9).
- 5** Provided is a circuit breaker that needs to be mounted between the positive battery terminal and the relay receptacle. Using the 12" piece of 10 gauge red wire and yellow terminals provided, connect the positive battery terminal to the circuit breaker and connect the circuit breaker to the short 10 gauge red wire of the relay harness.
- 6** Route the long 10 gauge red wire with the 18 gauge black wire of the relay harness to the air compressor mounting location. The red harness wire connects to the red wire of the air compressor motor with either one of the two unloader solenoid wires. Use the yellow heat shrink butt connector provided. The black 18 gauge wire of the relay harness connects to either one of the two terminals of the pressure switch.
- 7** Locate the short length of 18 gauge black wire and terminals provided. Connect one end of the black wire to the remaining terminal at the pressure switch. Using the eye terminal provided, connect the 18 gauge black wire with the remaining wire of the unloader solenoid with the 10 gauge black wire of the compressor motor securely to a good chassis ground. Provided is a 10 gauge black wire for an additional ground strap if necessary.
- 8** At the relay receptacle, route the red 18 gauge wire into the cab of the vehicle. Provided is an ON/OFF switch to control the air compressor. Locate a convenient location in the dash to install the switch, drill a 1/2" hole. Connect the red 16 gauge wire to the bottom terminal. Locate an ignition power source in the cab, using the blue "T" tap and the inline fuse provided, connect the ignition power source to the center terminal of the ON/OFF switch. The terminal in the upper corner of the switch is the ground for the light within the switch. Using the 12" piece of black wire provided, connect this terminal to a good chassis ground and then install the switch.

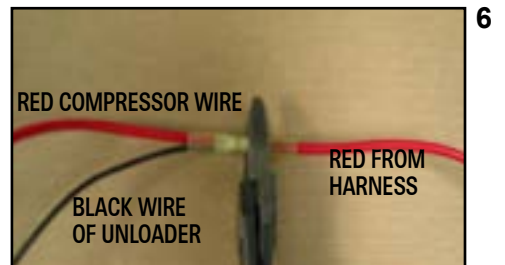

- 9 Install the relay into the receptacle. Secure all the electrical and airlines away from heat sources and moving parts with the tie-straps provided.

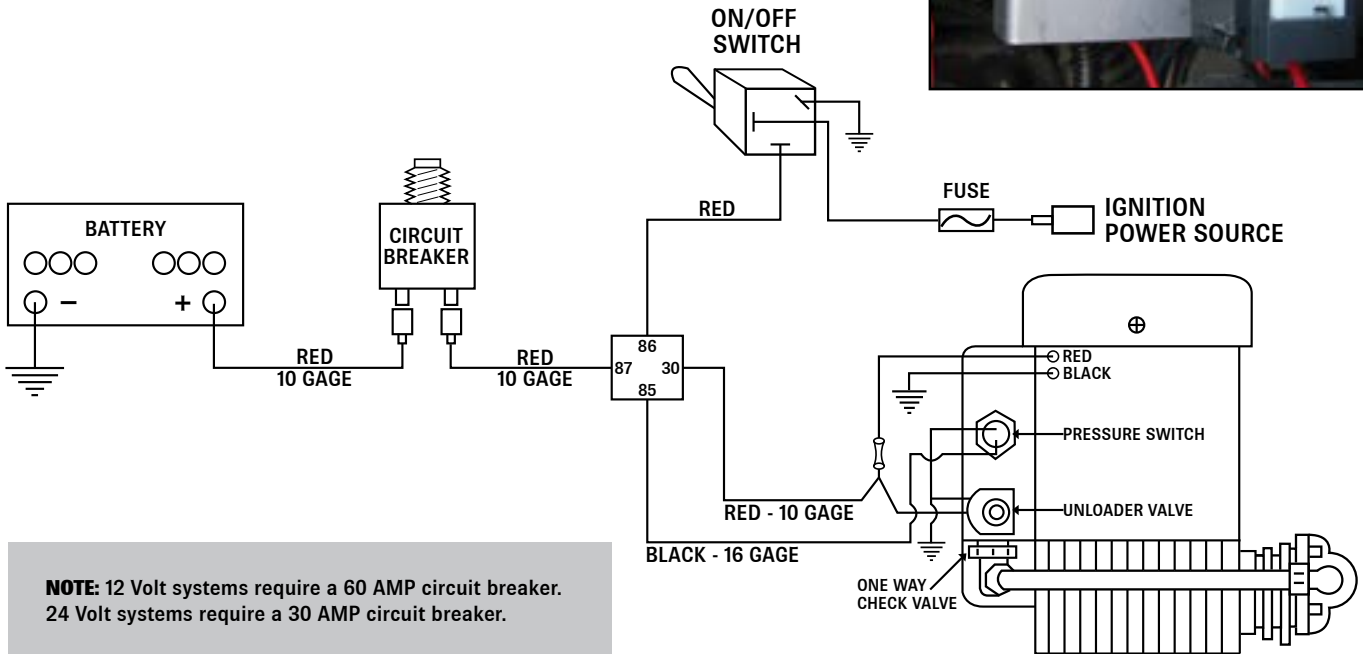

TESTING THE SYSTEM

To ensure correct air compressor operation, a long trouble free life and customer satisfaction, it is recommended the “cut in” and “cut out” pressures be verified.

If a permanent air pressure gauge is not being installed, temporarily install one into the air tank or manifold’s outlet port to verify the system operating pressure is with specifications.

Ensure the air compressor ON/OFF switch is OFF, then rotate the vehicles ignition switch to ON. (It is advisable to have the vehicle running while performing this test if multiple cycles of the compressor is performed). Turn the compressor ON/OFF switch to ON, the light in the end of the compressor ON/OFF switch should illuminate and the compressor should start to pump air. Watch the air pressure gauge as the compressor must turn off before 145 PSI is achieved. Then activate the accessory to reduce the air system pressure until the air compressor “cuts in” this should be no less the 95 PSI. The air compressor “cut in” and “cut out” pressures are a function of the pressure switch, if the “cut in” and “cut out” pressures are not suitable for the accessory being operated a different pressure switch is required. At this point it is advisable to soap test all the fittings for air leaks, correct all air leaks as they will cause the compressor to cycle more often. If the compressor does not perform as above, check all the wiring connections, power sources, fuse, circuit breaker and grounds to ensure good connections have been made.

For further assistance please call Pacbrake Customer Service @ 1.800.663.0096.