

Installation Manual

PACBRAKE®

www.pacbrake.com 800.663.0096



HP10247 KIT

Ford F250/F350* SUPERDUTY 4WD*

(With or Without Factory 5th Wheel Hitch)
(Single & Dual Rear Wheels)

* See application guide for proper fitment.

Use the most advanced air springs on the market to eliminate your vehicle's sag, sway and bottoming out. Pacbrake air suspension levels your truck's stance while providing added support for an overall smooth and safe ride.



KIT CONTENT

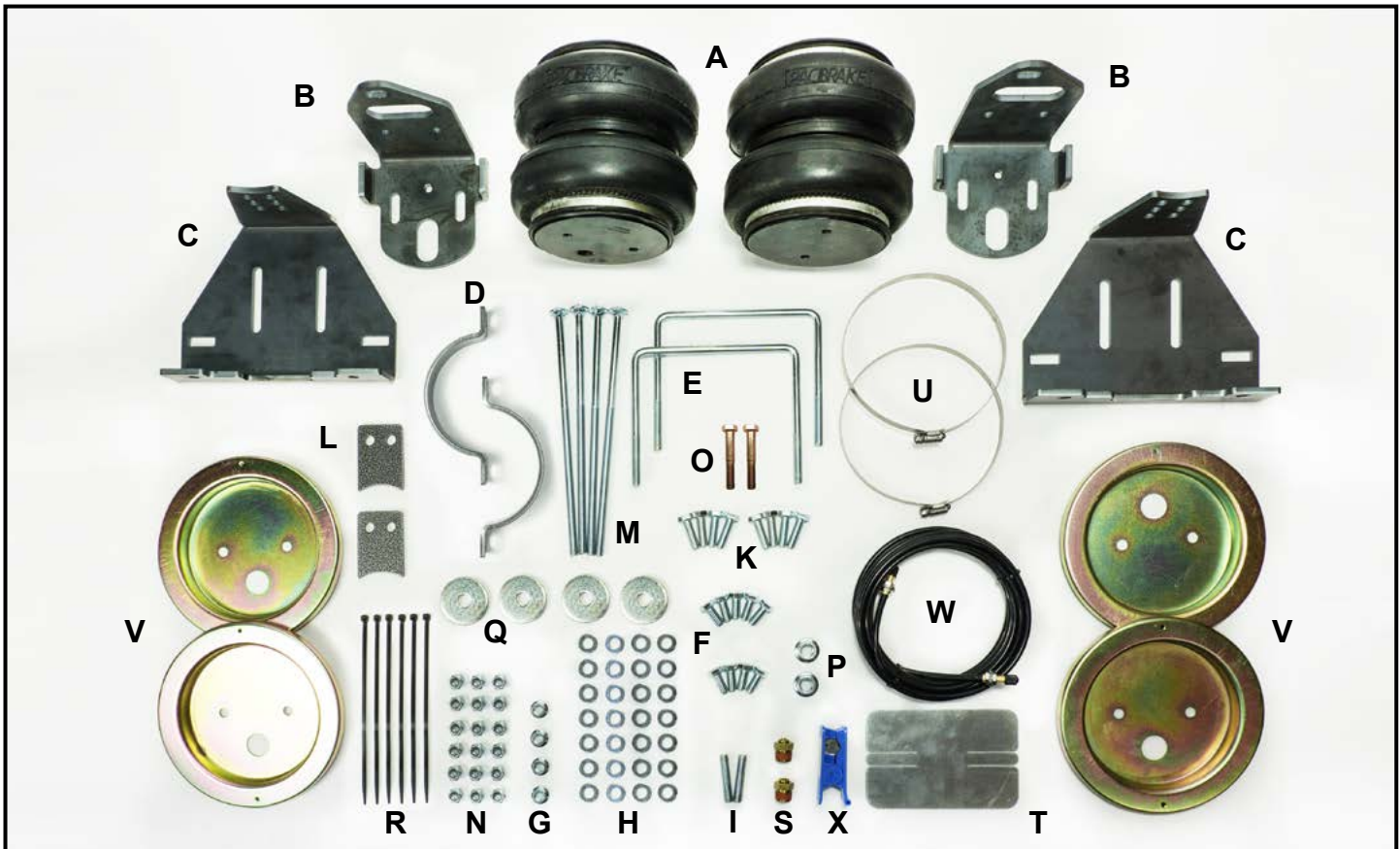

KIT CONTENTS

A	Air Spring	2	HP10068
B	Upper Bracket	2	HP1460
C	Lower Bracket	2	HP1461
D	Axle Strap	2	HP0007
E	3/8-16 U-Bolt	2	HP1015
F	3/8-24 x 7/8" Hex Head Screw	9	HP1002
G	3/8-16 Serrated Flange Nut	4	HP1338
H	3/8" Flat Washer	28	C653
I	3/8-16 x 2.000" Threaded Stud	2	HP1458
J	Hose Clamp	2	HP1001
K	3/8-16 x 1.250" Hex Head Cap Screw	8	C10464
L	Lower Bracket Spacer	2	HP0020
M	3/8-16 x 9" Carriage Bolt	4	HP1427
N	3/8-16" Nyloc Nut	18	HP1000
O	1/2-13 x 2.000" Hex Head Cap Screw	2	HP1459
P	1/2-13 Serrated Flange Nut	2	HP1370
Q	1/2" Fender Washer	4	HP1369
R	Tie Strap	6	C11618
S	3/8" NPT to 1/4" Tube Fitting	2	HP1385
T	Heat Shield	1	HP0012
U	Hose Clamp	2	HP1377
V	Roll Plate	4	HP10069
W	Air Line Assembly	1	HP1344
X	Tube Cutter	1	HP10208

REQUIRED TOOLS

- Ratchet and Socket Set
- Open or Box End Wrenches
- Torque Wrench
- Drill and 3/8" Sharp Drill Bit (5th Wheel Hitch Trucks Only)
- Pipe Thread Sealant
- Safety Stands
- Hoist or Floor Jack
- Safety Glasses
- Spray Bottle with Dish Soap & Water Mixture
- Air Compressor / Compressed Air Source

Make sure all the items shown in the photo are provided in your kit before starting the installation.

KIT CONTENTS

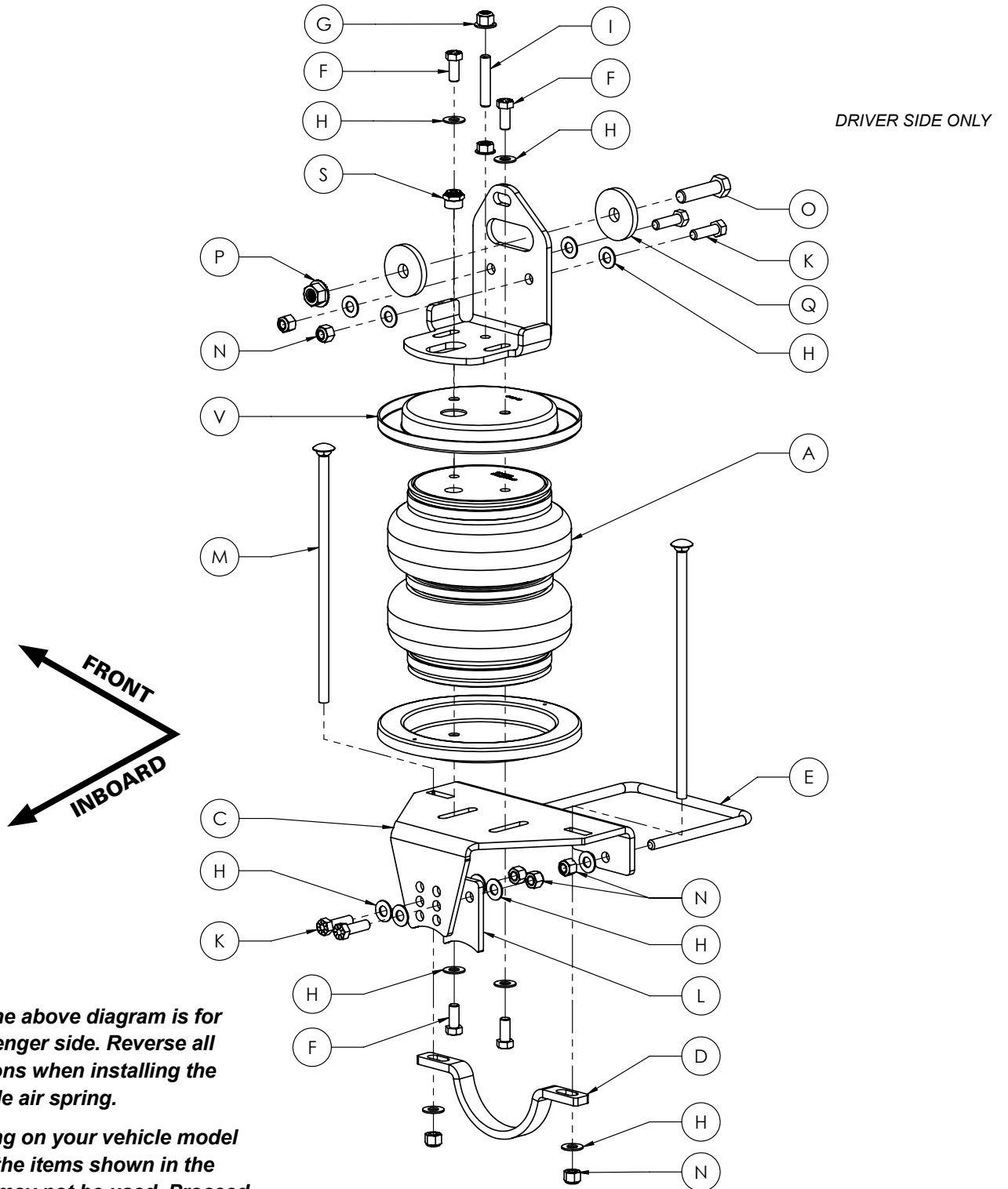

NOTE: The above diagram is for the passenger side. Reverse all orientations when installing the driver side air spring.

Depending on your vehicle model some of the items shown in the diagram may not be used. Proceed to the following page for installation instructions.

Thank you and congratulations on the purchase of an AMP air suspension kit. Please read the entire installation manual prior to starting the installation to ensure you can complete the installation once started.

IMPORTANT:

This air suspension kit will not increase the GVWR (Gross Vehicle Weight Rating), as the GVWR is determined by the axle rating. Do not exceed the maximum capacity listed by the vehicle manufacturer.

BEFORE YOU START:

NOTE: Some vehicles are equipped with a rear wheel brake proportioning valve. Check with the manufacturer before installing the air spring kit, as it may affect braking performance.

1. Ensure the application information is correct for the make, model and year of the vehicle you are installing the kit on.
2. Pacbrake recommends using a good quality anti-seize on all fasteners. This will reduce the chance of corrosion on the fasteners and will help facilitate removal, if required at a later date.

1 RAISE THE REAR AXLE

- Remove any unnecessary weight from the vehicle to attain normal ride height. This is important for correct initial air spring setup and adjustment.
- Park the vehicle on a level surface.
- Record the vehicle's normal ride height, which is the distance between the center of the axle and the horizontal wheel well flange. Ensure both sides are the same before raising the vehicle.
- Raise the rear axle high enough to remove both rear wheels and attain a comfortable working height.
- Place two jack stands under the chassis (photo 1A).
- Lower the floor jack until the vehicle chassis is supported by the jack stands.
- Ensure the normal ride height measurement recorded earlier is the same. Adjust if necessary before proceeding.
- Once the vehicle is raised correctly, remove the rear wheels.

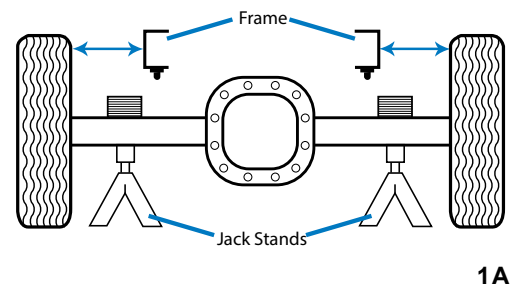

1A

2 REMOVE THE JOUNCE BUMPERS

- Use a 15 mm socket or box end wrench to remove the jounce bumpers. Return both the jounce bumpers and the nuts to the customer. They will not be used in the installation. See figure 2A.

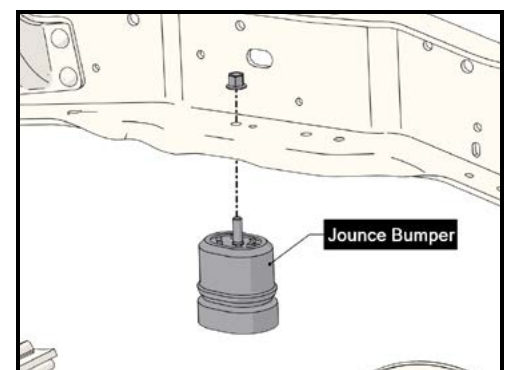

2A

3 ASSEMBLE THE AIR SPRINGS

CAUTION: This installation utilizes NPT air fittings. Never back off an installed air fitting. Loosening the fitting will corrupt the seal and contribute to leakage and failure. Apply thread sealant to the air fitting threads to prevent air leaks.

- Use an 1¹/₁₆" wrench to install a straight air fitting into the inlet of the air spring. Finger tighten and turn an extra 1.5-3.0 turns to tighten.
- Place a roll plate and upper bracket on top of the air spring as shown in Figure 3A. Fasten it to the air spring with two 3/8"-24 x 7/8" hex head cap screws, and two flat 3/8" washers. Finger tighten the cap screws to allow for adjustment later on. See figure 3A.
- Insert the threaded 3/8"-16 x 2" stud into the threaded hole in the upper bracket.
- Install a 3/8" flange nut onto the stud and torque the nut to 15 ft-lbs [20 N•m]. See figure 3B.

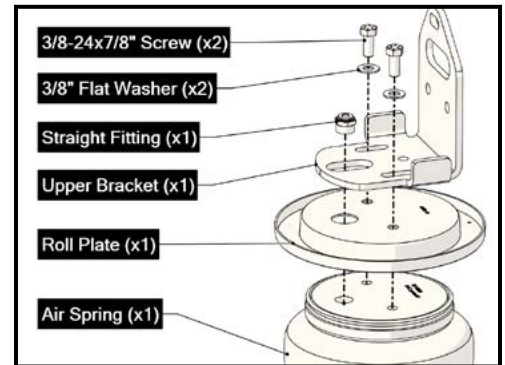

3A

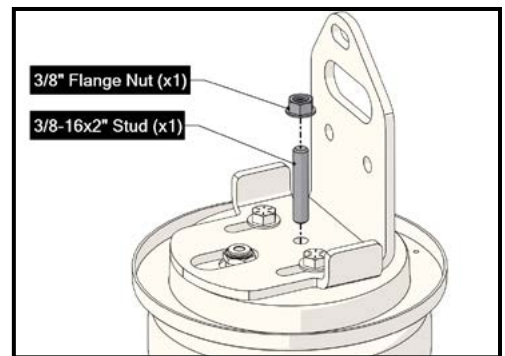

3B

- Place the lower bracket onto the jounce bumper tongue. See figure 3C.
- If the lower bracket is sitting level on the jounce bumper tongue proceed to the next step. If the lower bracket is not sitting level, install the spacer provided in the kit. See figure 3D. Use two 3/8"-16 x 1.25" hex head cap screws, four 3/8" flat washers and two 3/8" nyloc nuts, to secure the spacer to the lower bracket. Torque the hex head cap screws to 30 ft-lbs [41 N•m].
- Place a roll plate and lower bracket on the underside of the air spring. Fasten it together with two 3/8"-24 x 7/8" hex head cap screws, and two flat 3/8" washers. Finger tighten the cap screws to allow for adjustment later on. See figure 3E.
- Repeat this step for the other air spring.

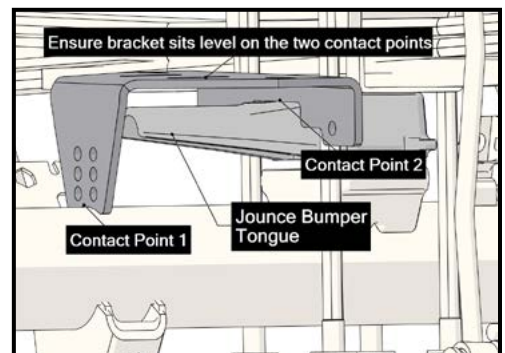

3C

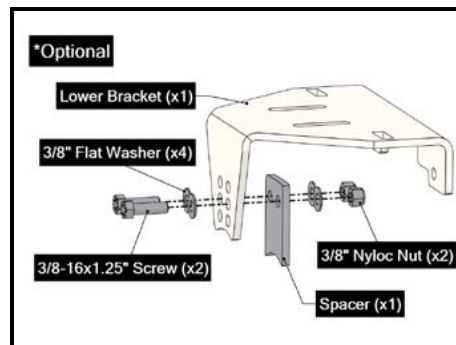

3D

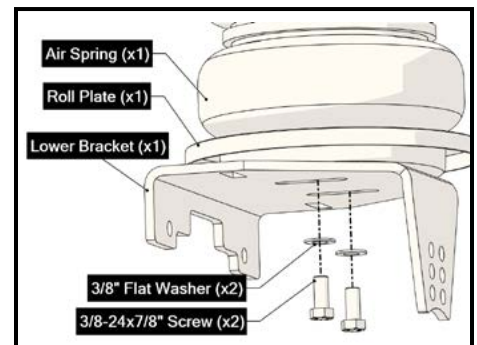

3E

4 UPPER BRACKET INSTALLATION

NOTE: If you have a factory installed 5th wheel hitch you will be required to drill two 3/8" holes into the frame rail. Check the other side of the frame rail before drilling any holes. Ensure that there are no brake lines, fuel lines or wiring that may interfere with the installation. Relocate the lines and/or wiring if necessary.

- **For driver side only:** Remove the 8 mm screw located on the outside of the frame rail and return to the customer. It will not be used for the installation. See figure 4A.
- Select one of the air spring assemblies and place it in between the frame and the axle as shown in figure 4B. It may be necessary to raise the body of the vehicle.

Note: Ensure that the stud on the upper bracket passes through the hole where the jounce bumper was originally mounted.

- Roughly align the air spring according to figure 5C. Once it is aligned, remove the air spring assembly from under the vehicle and torque the two hex head cap screws holding the upper bracket to the air spring to 20 ft-lbs [27 N•m]. Leave the hex head cap screws holding the lower bracket to the air spring loose.
- Reinstall the air spring assembly into the vehicle.
- Use one 3/8" flange nut to fasten the stud on the upper bracket to the frame rail. Torque the nut to 20 ft-lbs [27 N•m]. See figure 4C.
- **For vehicles without a factory installed 5th wheel hitch:** Place a 1/2" flat washer onto the 1/2-13 x 2" hex head cap screw and insert it through the slot in upper bracket. Use a 1/2" flat washer and 1/2" serrated flange nut to fasten the upper bracket to the frame rail. Torque the cap screw to 80 ft-lbs [108 N•m]. See figure 4D.

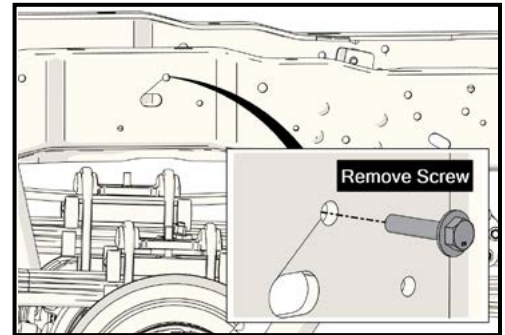

4A

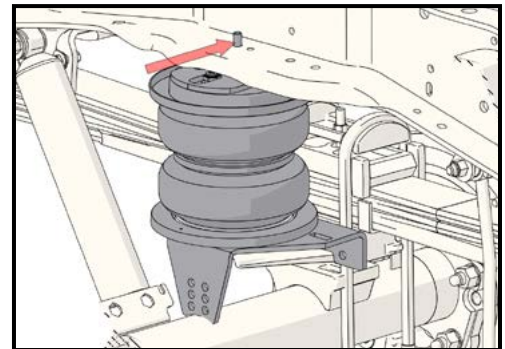

4B

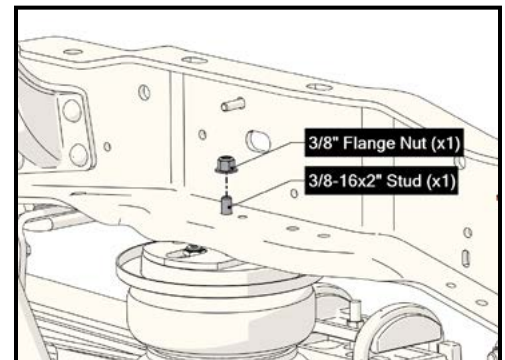

4C

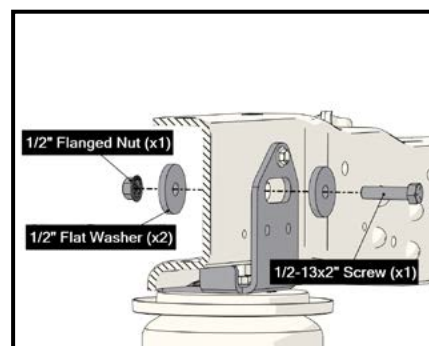

4D

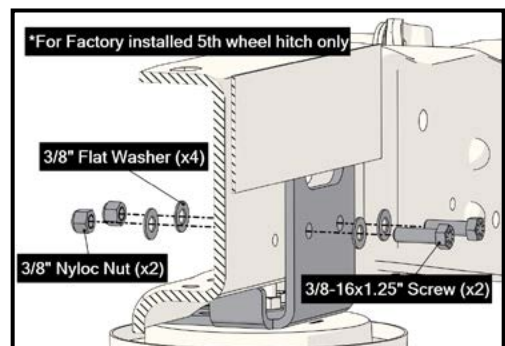

4E

4 UPPER BRACKET INSTALLATION CONTINUED

- **For vehicles with a factory installed 5th wheel hitch:** The factory installed 5th wheel hitch covers the slot for the 1/2" cap screw. You will be required to drill two 3/8" holes into the frame rail. See figure 4E.

Use the two lower holes on the upper bracket as a template and drill two 3/8" holes into the frame rail. See figure 4E. Fasten the upper bracket to the frame using two 3/8"-16 x 1.25" hex head cap screws, four 3/8" flat washers and two 3/8" nyloc nuts. Torque the hex head cap screws to 30 ft-lbs [41 N•m].

5 LOWER BRACKET INSTALLATION

- Place the 3/8" U-Bolt around the outside of the leaf pack U-bolts and through the holes in the lower bracket. Use two 3/8" flat washers, and two 3/8" nyloc nuts to fasten the U-bolt to the lower bracket. Torque both nyloc nuts to 15 ft-lbs [20 N•m]. See figure 5A.

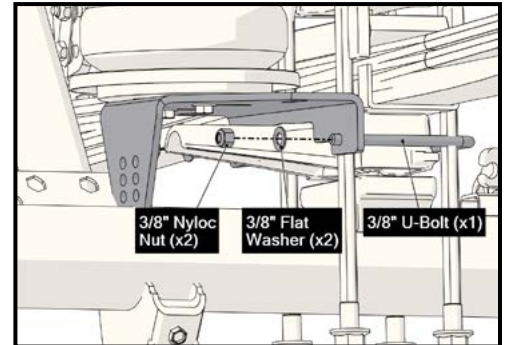

5A

- Insert two 3/8"-16 x 9" carriage bolts through the slots in the lower bracket as shown in figure 5B.
- Place the axle strap under the axle as shown in Figure 5B. Use two 3/8" nyloc nuts, and two 3/8" flat washers to secure the axle strap to the axle. Torque both nyloc nuts to 15 ft-lbs [20 N•m]. Refer to figure 5B.

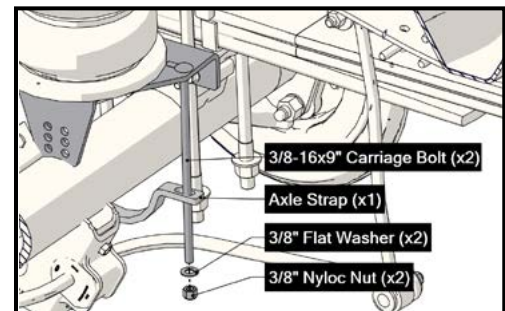

5B

NOTE: Ensure that the carriage bolts are not rubbing against any brake lines. Reposition either the carriage bolts or brake lines to prevent rubbing.

- Adjust the alignment of the air spring according to figure 5C.
- Torque the 3/8"-24 x 7/8" hex head cap screws holding the lower bracket to the air spring to 20 ft-lbs [27 N•m]. See figure 3E.
- Use the supplied fasteners to attach the cable clamp to the hole on the top face of the lower bracket. Use it to reposition anything contacting the air spring.

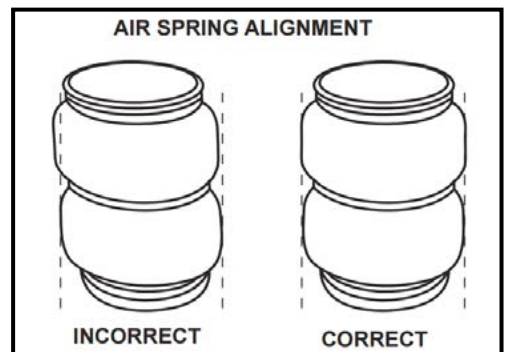

5C

6 HEAT SHIELD INSTALLATION

- Bend the tabs on the heat shield so there will be the necessary 1/2" dead space between the heat shield and the muffler when the heat shield is attached. See figure 6A.

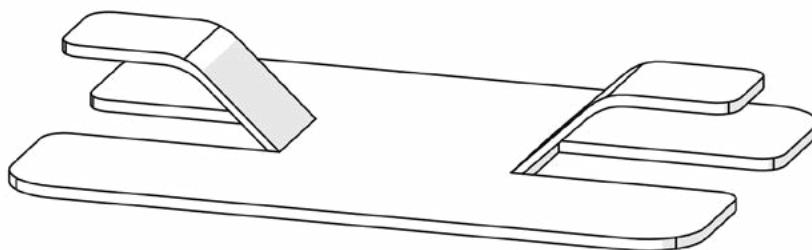

6A

6 HEAT SHIELD INSTALLATION CONTINUED

- Attach the heat shield to the exhaust pipe using two hose clamps. Each hose clamp holds a tab against the exhaust pipe. Make sure the heat shield is facing toward the air spring and that there is at least a 1/2" between the heat shield and the air spring. See figure 6B.

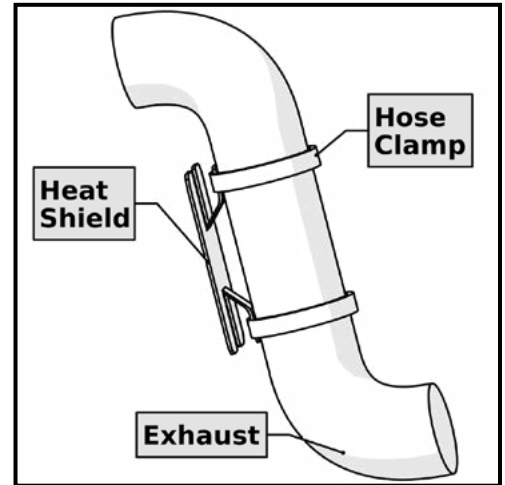

6B

7 AIR LINE INSTALLATION

- Provided in the basic air spring kit are two fill valves. The most common place to install them is to replace the license plate fasteners with the fill valves. Alternatively, two holes can be drilled in a convenient location. See image 7A.
- Install one airline according to figure 7B, route the nylon hose to an air spring fitting, cut the hose and connect to the air spring fitting. Repeat with the other fill valve.
- Secure the airlines away from moving items and heat sources with the tie straps provided in the kit.
- If an in cab inflation kit is being installed, follow the instructions provided with it.

NOTE: This kit contains push-to-connect fittings, using scissors or wire cutters to cut the nylon airline will distort the line and cause the connection to leak. THE AIRLINE MUST BE CUT OFF SQUARELY WITH A SHARP RAZOR KNIFE OR THE NYLON HOSE CUTTER PROVIDED IN THE KIT.



7A

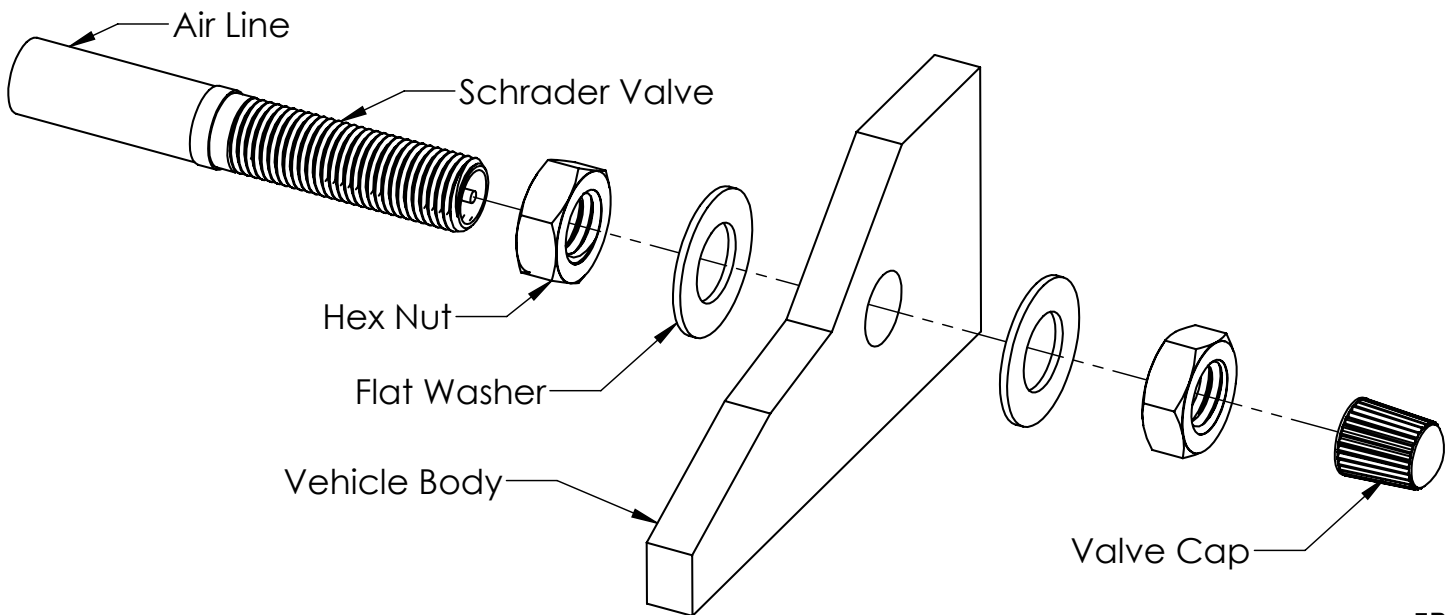

7B

8 CHECK THE SYSTEM FOR LEAKS

- Inflate both air springs to 90 PSI, and then use a mixture of dish soap and water on all air line connections to detect any air leaks. Repair as necessary and retest.
- Inflate the air springs to a predetermined value, and on the following day recheck the pressure. If one or both the air springs have lost pressure, an air leak is present. The leak must be repaired, and then retested until no leaks exist.

9 AFTER THE INSTALLATION IS COMPLETED, PLEASE REMEMBER

- Install the wheels, and torque the fasteners to the manufacturer's specifications.
- Re-torque all the fasteners after the first 500 miles of driving.
- For safe and proper operation, never operate the vehicle under the minimum of 10 PSI or over the maximum of 100 PSI. Staying within the pressure limit will ensure maximum air spring life. Failure in doing so may void the warranty.



8A

OPTIONAL ACCESSORIES

Pacbrake offers an optional dual needle air gauge to monitor the pressure in each spring from the vehicles cab. Pacbrake offers a full line of air compressors, air tanks and solenoids to control your air spring system.

OPERATING YOUR VEHICLE WITH PACBRAKE AIR SUSPENSION

Air springs have minimum and maximum pressure requirements. Never operate your vehicle with less than 10 PSI in the air spring and never inflate the air springs over 100 PSI. Staying within the pressure limit will ensure maximum air spring life. Failure in doing so may void the warranty. Check the air pressure in the air springs daily for the first couple of days to ensure a leak does not develop. The air springs are designed to maintain the vehicles stock ride height with a load. Do not use the air springs as a means to lift the vehicle with no load. A rough ride will result.

SERVICING YOUR VEHICLE WITH PACBRAKE AIR SUSPENSION

When lifting the vehicle with a floor jack or hoist on the frame, never allow the air spring to limit the travel of the axle. Try to always jack the vehicle on the axle. Suspending the axle with the air spring limiting the axle travel will damage the air spring and void the air spring warranty.

WARRANTY

To be eligible for warranty, owner must submit their warranty card or register online within 30 days of purchase date.

NOTE: The owners warranty will be void if air springs run with less than the minimum of 10 PSI.