

SUBJECT

**Master Piston Conversion Kit
Converts P-80 Master Piston Assembly
to P-80A Assembly**

PART NUMBER

P80051

APPLICATION

**Detroit Diesel Series 60
MY2001/2002 12.7L/14.0L**

Removal Of The Housings From The Engine

- 1** Clean the engine around the valve cover and check the gasket for defects, as a new one is not supplied. Order a new one if necessary. On two piece valve covers, remove the top only.
ATTENTION: Before removing the housings, make certain the serial number tag reads P-80 and NOT P-80A and the housing serial numbers are between 80000 and 92499 or 800000B and 800156B.
- 2** Remove wires to the solenoids.
- 3** Loosen the housing hold down bolts evenly.
- 4** Remove both housings from the engine.

Disassembly And Assembly Of The Brake Housings

- 1** Place the housings on a clean work bench.
Note: When removing all parts keep them in order of their original location for assembly later.
- 2** Remove the control valve retaining rings. **Use caution** and wear eye protection, as the washers are under spring pressure! Remove the springs. Check the control valves to ensure they slide in and out easily using needle nose pliers or a magnet. If not, inspect the bore and control valve for damage. Discard used inner control valve springs only. Reassemble in reverse order using the replacement inner control valve springs supplied.
- 3** Turn the housings over to remove the master piston retainers. A heat gun may be required to remove the capscrews as Loctite is applied at assembly. Check the piston to ensure it slides in and out easily. If not, inspect the bore and piston for damage. Discard capscrews, springs, washers, retainers and links. Use only the retrofit parts supplied.
- 4** The retainers supplied have 3 holes to cover both single and dual hole applications. Reuse the master piston from the P-80 system. The parts supplied in this kit must be installed as an assembly. The retainer capscrews have a patch on the threads, loctite is not necessary.
Assemble all parts into the housing using clean engine oil in the reverse procedure. Master piston return spring **MUST** be installed with the larger end against the washer and retainer. Torque master piston retainer capscrews, PN P80012 to 65 in.lbs.
Note: Make sure all retaining rings are seated in their groove.
- 5** Install on engine as per Pacbrake Installation Manual. For a copy of the installation manual visit our site at www.pacbrake.com
- 6** Record brake serial numbers, engine numbers and truck numbers for your records.

Installation PROCEDURES

SUBJECT

Master Piston Conversion Kit
Converts P-80 Master Piston Assembly
to P-80A Assembly

PART NUMBER

P80051

APPLICATION

Detroit Diesel Series 60
MY2001/2002 12.7L/14.0L

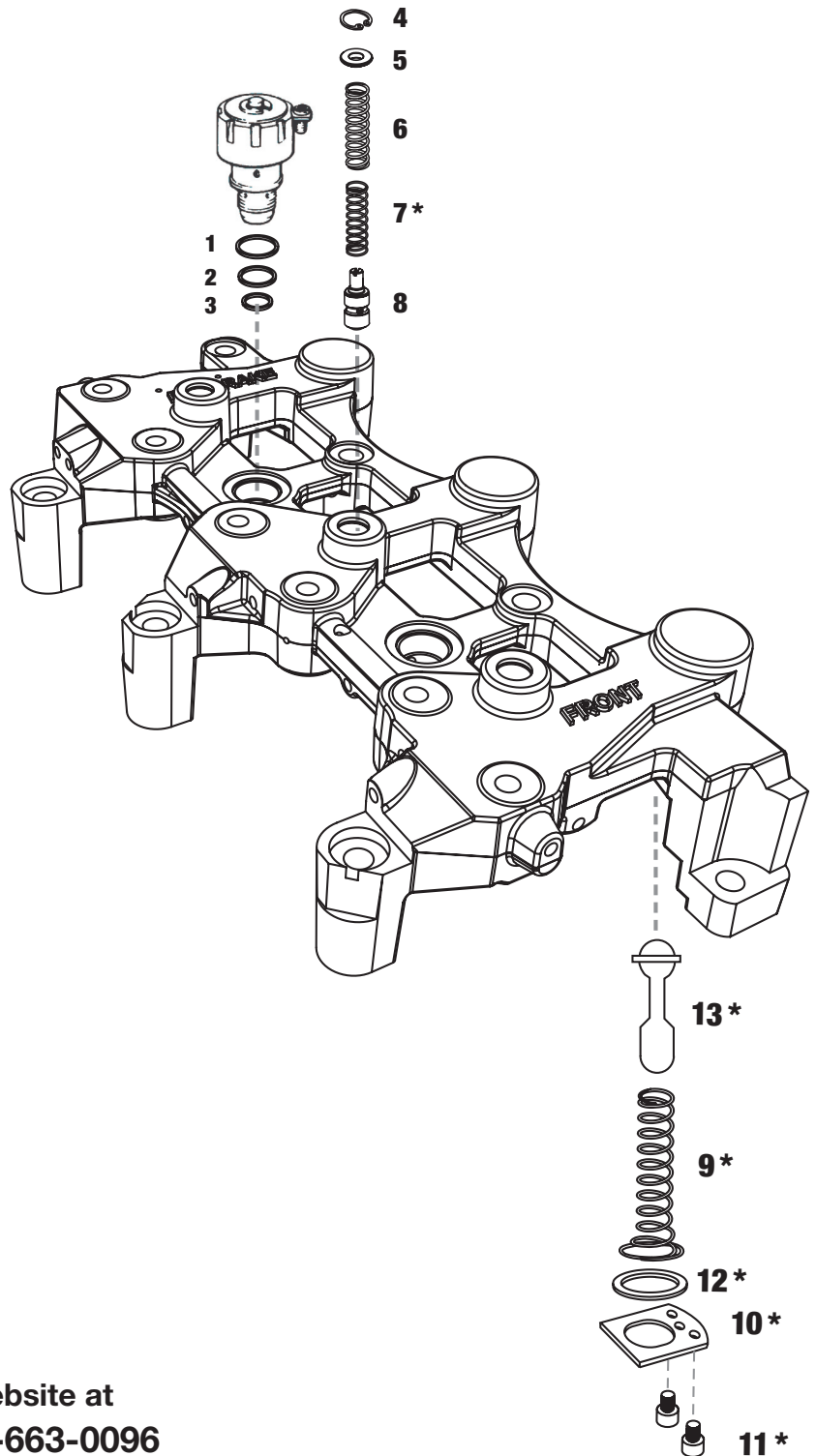

ILLUS.#	PART #	DESCRIPTION	QTY.
1	P01081	Upper Solenoid Viton Seal	3
2	P01082	Center Solenoid Viton Seal	3
3	P01083	Lower Solenoid Viton Seal	3
4	P15561	Snap Ring	6
5	P38015	Plain Washer	6
6	P11434	Outer Control Valve Spring	6
*7	P11435	Inner Control Valve Spring	6
8	P01500	Control Valve	6
*9	P80031	Master Link Spring	6
*10	P80038	Master Piston Retainer	6
*11	P80012	Socket Head Retaining Screw	12
*12	P80030	Washer	6
*13	P80033	Master Piston Lnk	6

* PARTS CONTAINED IN THIS KIT

For Additional Information visit our website at
www.pacbrake.com or call 1-800-663-0096